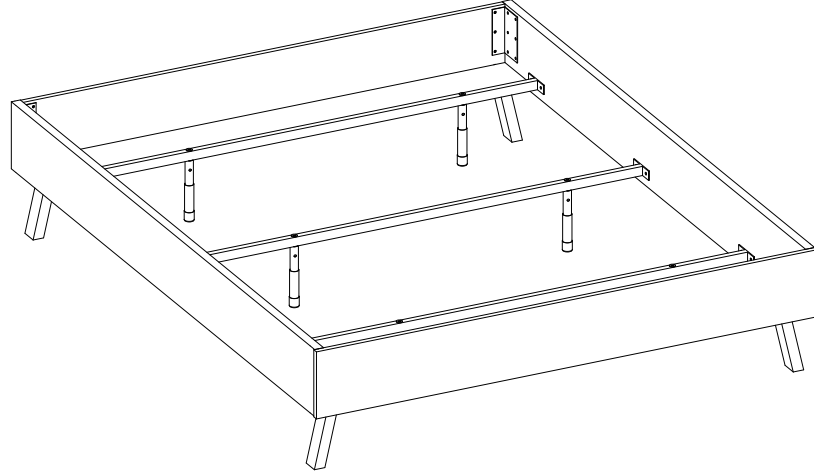

ÜRÜN KODU / Product code / Produkt kode**3200409841****ÜRÜN ADI / Product name / Produkt name****SENTA 83029 160CM KARYOLA****ÜRÜN EBADI / Product Size / Produkt Dimensionen****1675 x 2060 x 420****Bu modül iki kişi tarafından kurulmalıdır.**

This unit should be assembled by two persons.

Dieser artikel sollte von zwei personen montiert werden.

**Bu modülün kurulumu için gerekli olan araçlar.**

The necessary tools (not included)

Die dazu benötigten Werkzeuge (ausschliesslich)



Sayın Müşterimiz,

Satınalmış olduğunuz bu ürün sizlere ulaşmadan önce tarafımızdan her türlü kontrol ve testlere tabii tutulmuştur. Bu durumda bile taşıma sırasında bazı parçaların zarar görmesi mümkündür. Böyle bir durum ile karşılaşırsanız ürünün tamamını geri göndermeyiniz. Sadece zarar gören parçayı isteyiniz. Gerekli parçayı isterken ise servis kartına bakarak tam olarak tanımlayınız. Eksik olan parça en hızlı şekilde tarafınıza gönderilecektir.

Montaja başlamadan önce kutulardan çıkan tüm parça ve aksesuarları listelere göre kontrol ediniz. Parça ve aksesuarların tam ve sağlam olduğunu tespit ettikten sonra montaja başlayınız.

Montaja başlamadan önce her parçayı nemli bir bez ile temizleyiniz.

Eğer birden fazla ürün aldıysanız herhangi bir karışıklığa sebep vermeme için tek bir ürün montajını yaptıktan sonra diğer ürüne geçiniz.

Ürünleri hiçbir zaman sürterek taşımayınız. Ürünü kaldırarak ve sökerek en az iki kişi ile taşıyınız. Uzun mesafeli taşımalarda ürünü mutlaka paket ile taşıyınız.

Almış olduğunuz mobilyalarının yüzeylerinin temizlenmesi çok kolaydır. Nemli ve sabunlu bir bez ile veya diğer ev temizleyicileriyle silmek yeterlidir.

Mobilyalar aşırı sıcak, soğuk ve nemden etkilendiklerinden, mobilyanızı bu faktörlerle direkt olarak temas ettirmeyiniz.

Mobilyanızı amacı dışında kullanmayınız.

Dear Customer,

The product you bought was subjected to all sorts of tests and control before sending out to you. Even in this situation, sometimes happen that some component is damaged during the transportation. In such case please do not send the whole article back to us. Just request/order the damaged part. While requesting the required part, describe it exactly by looking to service card. Missing part will be sent to you as soon as possible.

Before start assembling, please check the whole components and accessories according to the lists. After being sure that every part and accessory are okay and right, start assembling.

Before start assembling, please clean all the components with a damp cloth.

If you bought more than one product, to prevent confusion be sure that you completed the first product. Then start the other product's assembling.

Never draw the products. While carrying, disassociate and lift the product and carry with minimum 2 people. For long distances carry the product with the package.

It is very easy to clean the surfaces of your product. It is enough to wipe with a damp and soapy cloth or other household cleaners. Do not directly contact your furniture with excessive heat, cold and humidity because the product can be affected.

Do not use your furniture for out of purposes.

Lieber Kunde,

das von Ihnen gekaufte Produkt durchläuft verschiedene Tests und Prüfungen bevor es zu Ihnen kommt. Trotzdem kann es vorkommen, dass während des Transports ein Teil beschädigt wird.

In solchem Fall bestellen Sie anhand der Servicekarte das beschädigte bzw. das fehlende Teil. Wir werden Ihre Anforderung sofort bearbeiten und Ihnen das Ersatzteil umgehend zusenden.

Kontrollieren Sie vor der Montage anhand der Zubehörliste alle Teile und Accessoires auf Vollständigkeit. Erst nach dieser Überprüfung können Sie mit der Montage beginnen.

Falls Sie mehr als ein Produkt gekauft haben, montieren Sie erst das eine und danach das andere Produkt, damit Sie mit den Teilen nicht durcheinander kommen.

Der Transport von fertig montierten Möbeln sollte immer von zwei Personen erfolgen.

REINIGUNG

Reinigen Sie die Teile mit einem leicht feuchten Tuch, danach trockenreiben. Keine scheuernden oder ätzenden Reinigungsmittel verwenden.

Hohe Hitze und Feuchtigkeit schaden Ihren Möbeln, bitte von diesen Quellen fernhalten.

Möbel bitte nicht zweckentfremden.

NO	Stok Kodu	Malzeme Tanımı	Miktar	Birim	Net Boy (mm)	Net En (mm)	Net Kalınlık (mm)
	2200291911	KUTU-1 SENTA 83029 160CM KARYOLA	1	ADT			
1	2100347599	83029 DOENMIS YAN SAG	1	ADT	2033	220	18
2	2100347602	83029 DOENMIS YAN SOL	1	ADT	2033	220	18
3	2100347605	83029 DOENMIS AYAKUCU	1	ADT	1681	220	18
	2200291912	KUTU-2 SENTA 83029 160CM KARYOLA	1	ADT			
4	2200291921	BASUCU BAGLANTI PLAKASI	1	ADT	1615	219	18
5	2200291925	AYAK BAGLANTI KAYITI	2	ADT	1615	150	25
	2200291913	KUTU-3 SENTA 83029 160CM KARYOLA/AKS.	1	ADT			
6	2200291916	AKS.POS. 83029 160CM KARYOLA	1	ADT			
	2200291914	KUTU-4 SENTA 83029 160CM KARYOLA/YTKALT	1	ADT			
7	2200182692	YATAK ALTI SUNTASI DELIKLI(81400)	1	ADT	2005	530	18
8	2200182694	YATAK ALTI SUNTASI(81401)	2	ADT	2005	530	18
	2200291915	KUTU-5 SENTA 83029 160CM KARYOLA/MTK713P	1	ADT			

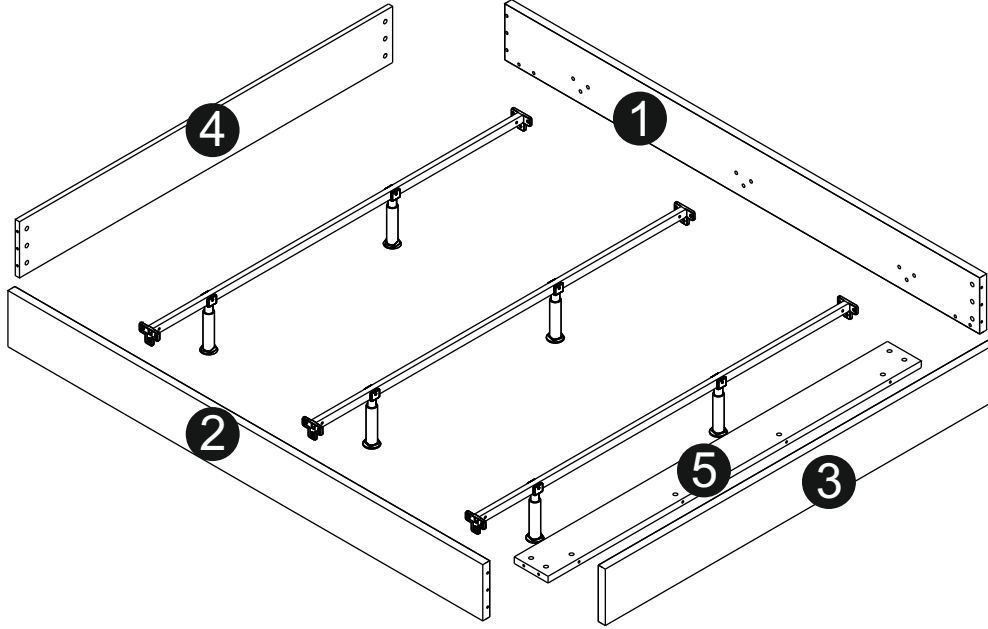

AKSESUAR LİSTESİ / Accessory List / Zubehör Liste

A5	MINİFİKS GÖVDE NİKL 015x13,2_108020_SMT	8x	1120007871	A1	MINİFİKS GVD 015x17mm_102-01-07 0177_MSN	16x	1120008106	A6	EKSANTRİK MINİMİLİ MESAN 0185-2	24x	1100006363	A12	KAVELA Ø8x30 MM PLASTİK	8x	1100006324	B23	KOSE BAGLANTI ELEM. M-50 YATAK	2x	1100006027	A58	VIDA YHB 4.0x20 SUNTA	12x	1100006390
A89	VIDA MB M-6X15BEYAZ	18x	1100006469	AHP1275P4	SENTA KARYOLA AYAK	1x	1120041122	A59	VIDA YHB 4.0x25 SUNTA	16x	1100006391												



1

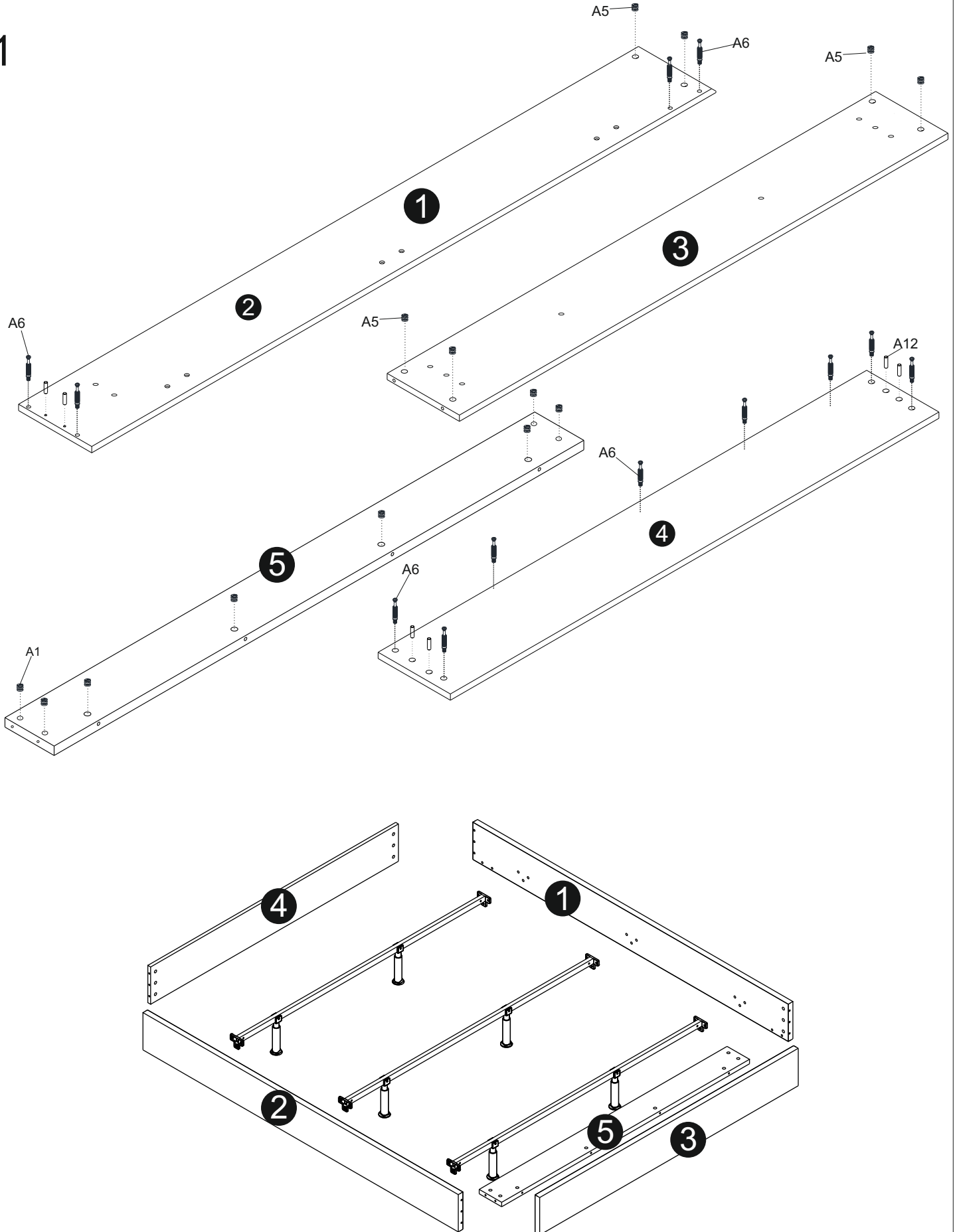

2

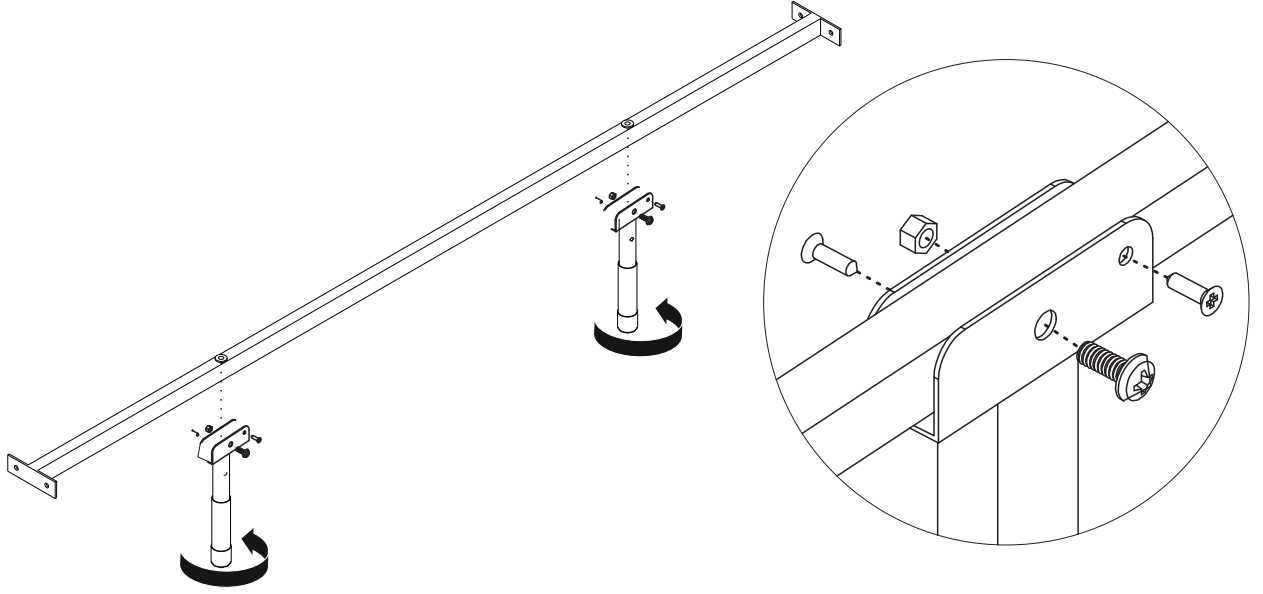

3

